

Smart lift SL608 Outdoor

Produktinformasjon og spesifikasjoner

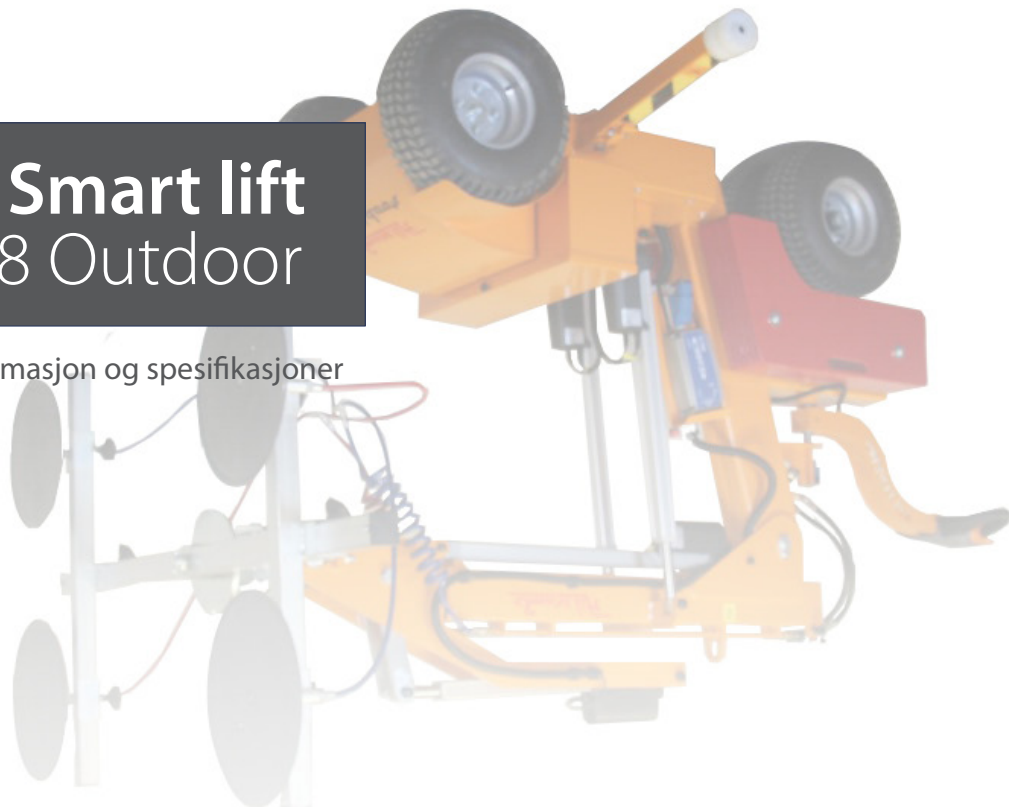

Smart lift SL608 Outdoor

STANDARDUTSTYR

- Utenfor vei med forhjulsdrift
- Doble bakhjul
- Skumfylte dekk
- Selvkjørende
- Løfthøyde på 3500 mm (sentrum av åk)
- Vanntett, ifølge miljøstandard ip65
- Elektronisk brems
- 4 sugekopper med Ø 400 mm
- Ergonomisk driftshåndtak
- 2-krets vakuumsystem med to pumper

DIMENSJONER



Vidde (minimum)	830 mm
Lengde (minimum)	2340 mm
Forlengelse av arm	700 mm
Sideforskyver	100 mm²



Høyde	1530 mm
Løfthøyde	3500 mm
Løftekapasitet (arm inne / utvidet)	608 / 280 kg
Spissen fra horisontalen	35° baklengs / 100° forlengs



Batteri (2 x 12 V) 24 volt	2 x 105 A
Brukertid	Approx. 20 hours
Integrert lader	Cetek XT 14000
ladetid	Omtrent 20 timer
Antall volt på lader	230 volt



Regulering av fart	Trinnløst høyt/lavt
Forhjuldrift	1200 Watt-AC
Brems	Elektrisk



Vakuumsystem	2-krets
Sugekopper	4 stk. Ø 400 mm



Vekt	830 kg
------------	---------------

BELASTNINGSDIAGRAM

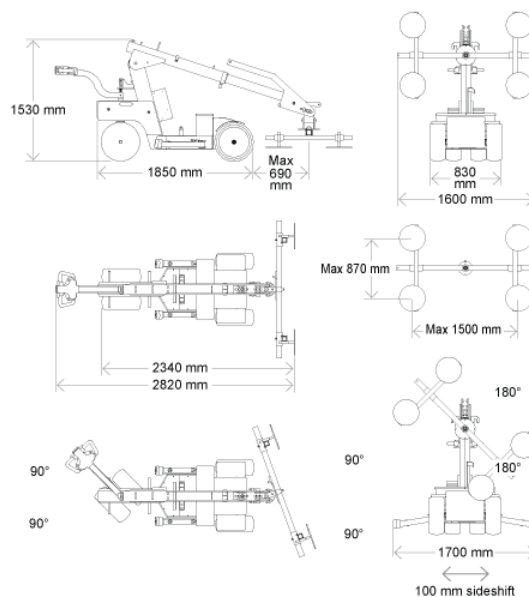
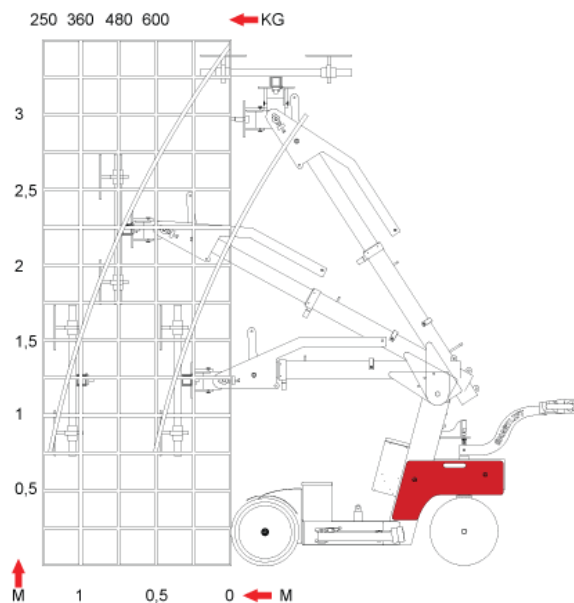

www.instant.no

INSTANT

Norway

Tel.: +47 23 19 11 00
info@instant.no

Lithuania

Tel.: +370 5 233 1096
info@instant.lt

Latvia

Tel.: + 371 263 58 152
info@instantlatvija.lv

Estonia

Tel.: +372 680 76 33
info@instant.ee